

APOLO

C O N F O R T

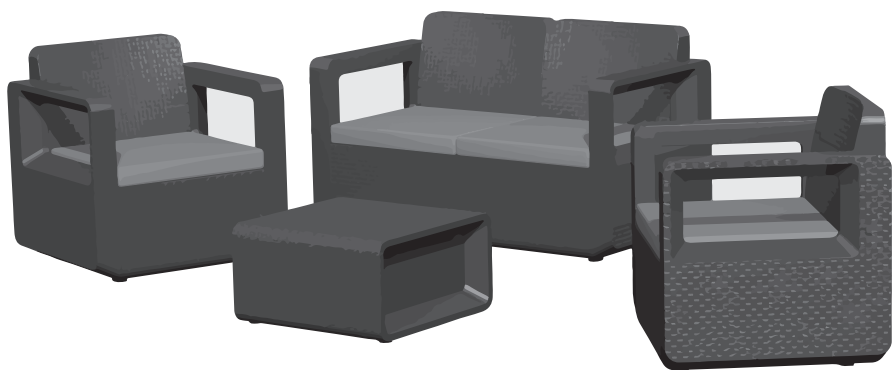

LEA CUIDADOSAMENTE LAS INSTRUCCIONES DE USO. GUARDAR TODAS LAS ADVERTENCIAS POR SI LAS NECESITA EN UN FUTURO!

**READ INSTRUCTION MANUAL !
KEEP ALL THE INSTRUCTIONS IN A SAFE PLACE FOR FUTURE REFERENCE !**

IMPORTANTE, CONSERVARE TUTTE LE ISTRUZIONI PER FUTURI RIFERIMENTI: LEGGERE ATTENTAMENTE

IMPORTANT, CONSERVER CES INSTRUCTIONS POUR UNE UTILISATION ULTERIEURE

É FAVOR LER CUIDADOSAMENTE AS INSTRUÇÕES. GARDE TODAS AS INSTRUÇÕES PARA O CASO DE NECESSITAR DELAS FUTURAMENTE

WICHTIG, BEHALTEN FÜR ZU ZUKÜNFTIGE HINWEISE: ACHTSAM LESEN !

Notas y Advertencias: Lea atentamente antes del montaje.

ES

Cada una de las piezas lleva grabada la letra con la que se le identifica.
 Por favor, montar cada pieza de mobiliario en una superficie plana.
 Una llave dedicada se adjunta para el montaje.
 Se recomienda montar los tornillos y las tuercas manualmente, apriete con la llave al final del proceso de montaje.
 Es muy recomendable que conserve la llave para su uso futuro.
 El mueble sólo se debe limpiar con agua, jabón y un paño suave.
 Los muebles están destinados exclusivamente para uso doméstico razonable.
 Se recomienda una vez montado el mueble, no desmontarlo

Notes and Warnings: Read carefully before assembly.

EN

Each part is engraved with the letter it identifies with. Please assemble each piece of furniture on a flat surface.
 A dedicated wrench is enclosed for assembly.
 It is recommended to assemble the screws and nuts manually, tighten them with the enclosed wrench at the end of the assembly process.
 It is highly recommended that you retain the wrench for future use.
 The piece of furniture should only be cleaned using soap, water, and a soft cloth.
 The pieces of furniture are exclusively intended for reasonable domestic use.
 It is recommended once the furniture is assembled, do not disassemble.

Note e avvertimenti: Leggere attentamente prima dell'assemblaggio.

IT

Ogni pezzo ha la lettera di identificazione inciso. Si prega di assemblare ogni mobile su una superficie piana.
 Nel set è inclusa una chiave apposita da utilizzare per l'assemblaggio.
 Si raccomanda di montare le viti e dadi manualmente, stringere con la chiave inclusa alla fine del processo di assemblaggio.
 Si consiglia vivamente di conservare la chiave per un uso futuro.
 Il mobile deve essere pulito con sapone, acqua e un panno morbido.
 I mobili sono destinati esclusivamente per uso domestico.
 Si raccomanda che una volta assemblati i mobili, non smontare.

Notes et avertissements: Lire attentivement avant le montage.

FR

Chacune des pièces porte une lettre identificatrice gravée.
 S'il vous plaît assembler chaque pièce de mobilier sur une surface plane. Une clé dédiée est enfermée pour l'assemblage.
 Il est recommandé d'assembler les vis et les écrous à la main, serrez-les avec la clé figurée à la fin du processus d'assemblage.
 Il est fortement recommandé que vous conserviez la clé pour une utilisation future.
 Le meuble doit être nettoyé avec du savon, de l'eau et un chiffon doux.
 Les meubles sont exclusivement destinés à un usage domestique raisonnable.
 Il est recommandé de ne pas démonter le meuble une fois monté.

Instruções: é favor ler cuidadosamente as instruções

PT

Cada peça tem gravada a respetiva letra de identificação. Montar cada peça de mobiliário sobre uma superfície plana.
 Chave especial fornecida para a montagem.
 Recomenda-se a montagem manual dos parafusos e porcas, apertando-os com a chave no final do processo.
 Recomenda-se que guarde a chave para eventual utilização futura.
 A limpeza deve ser feita com água, sabão e um pano macio.
 Recomenda-se que, uma vez montado, não se desmonte o móvel

Hinweise und Warnungen:Lesen Sie sorgfältig vor der Montage.

DE

In alle Teile ist zur Kennzeichnung ein entsprechender Buchstabe eingraviert.
 Möbelstück zur Montage auf ebene Fläche stellen. Ein passender Schraubenschlüssel für die Montage liegt bei.
 Es wird empfohlen die Schrauben und Muttern mit beiliegendem Schlüssel von Hand festzuziehen.
 Bitte bewahren Sie den Schlüssel unbedingt für eine spätere Verwendung auf.
 Die Möbelstücke bitte nur mit Wasser, Seife und einem weichen Tuch reinigen.
 Die Möbelstücke sind ausschließlich für den privaten Gebrauch gedacht.
 Nach dem Aufbau des Möbelstückes empfiehlt es sich nicht dieses wieder zu demontieren.

Sillón símil rattan
Rattan style Armchair
Fauteuil aspect rotin
Rattan stil Sessel

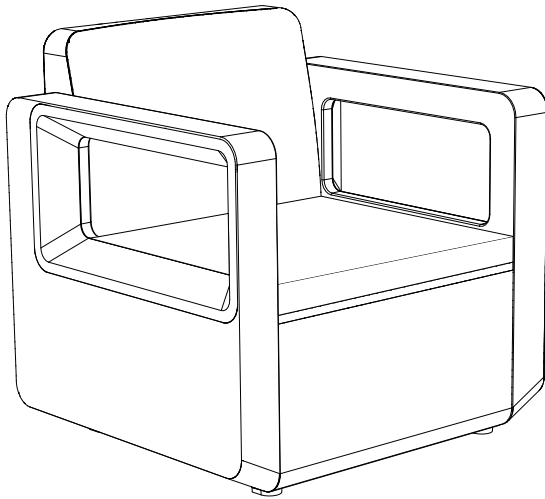

SHAF

ASSEMBLY PARTS - COMPOSANTS-COMPONENTES- BESTANDTEILE

A

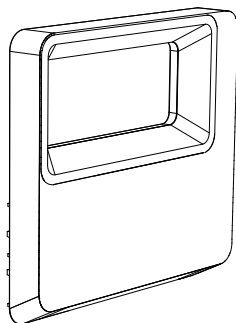

B

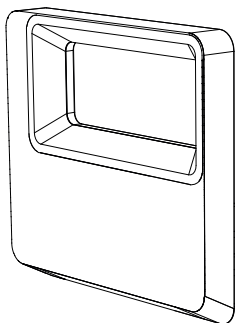

C

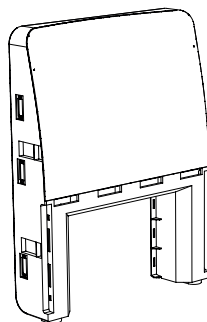

D

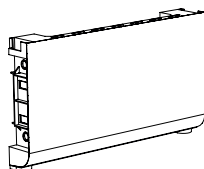

E

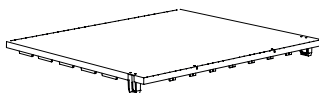

G

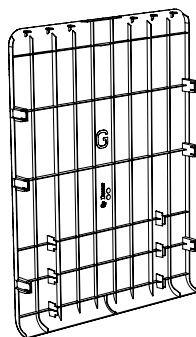

H



x2

I



x2

S



x4

U



VD

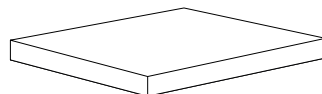

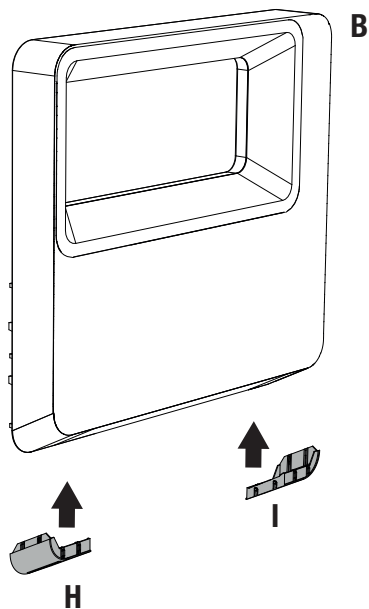
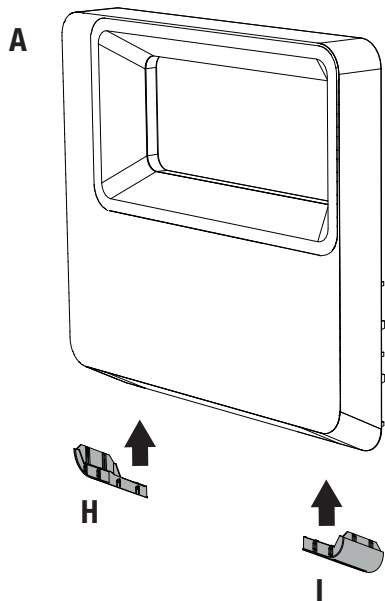

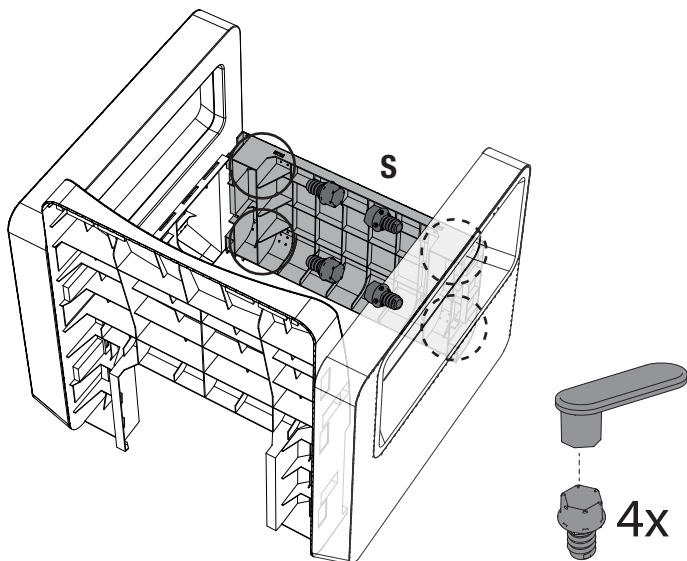
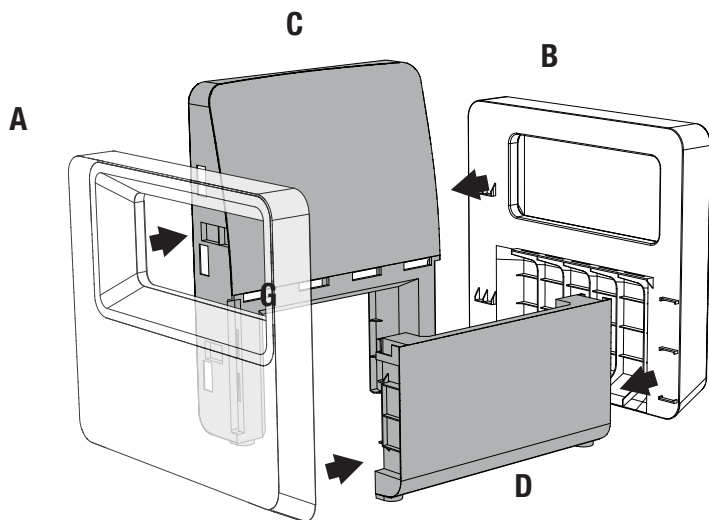

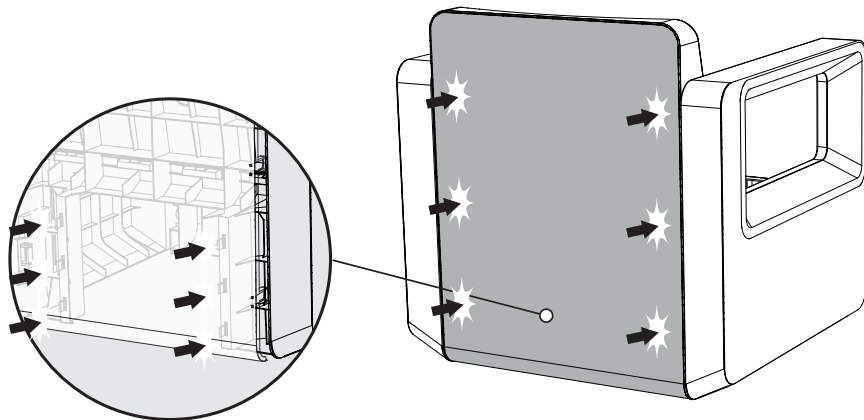
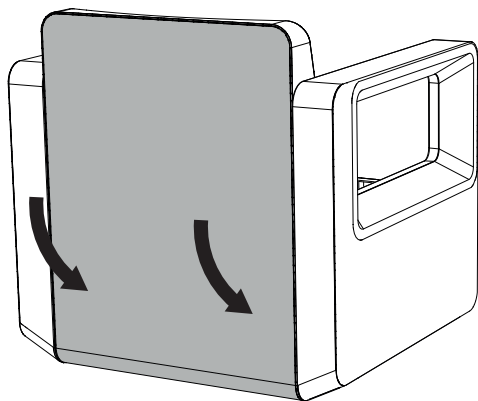
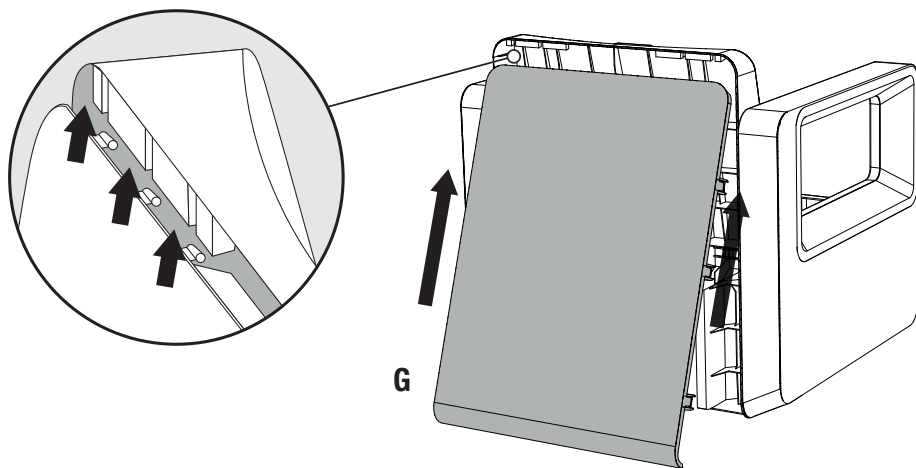

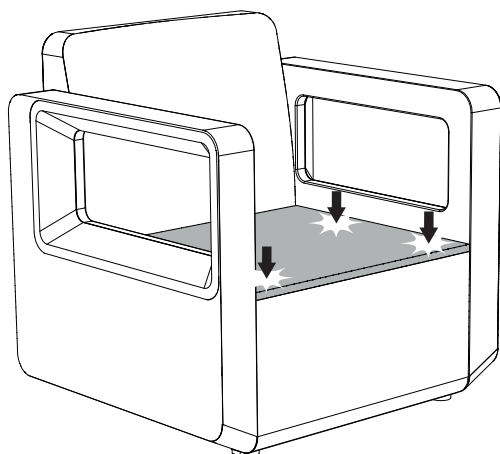
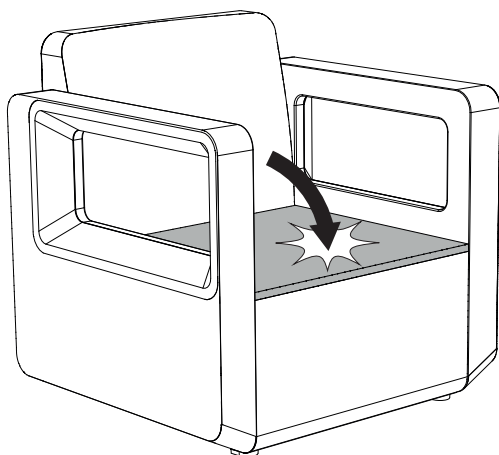
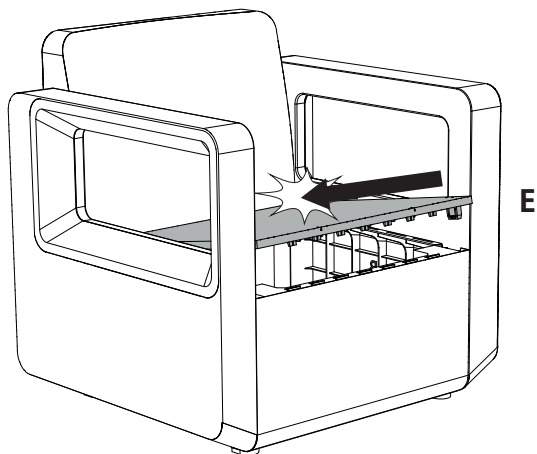

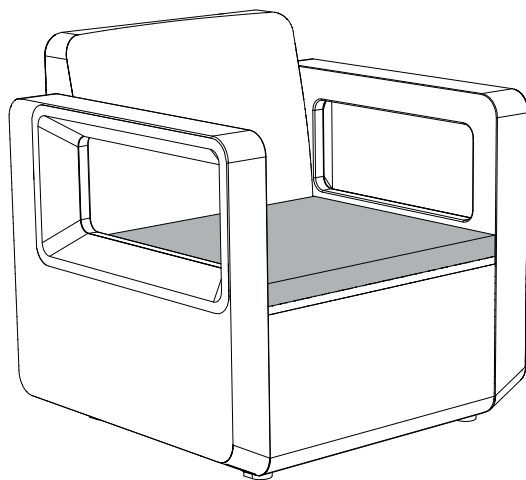
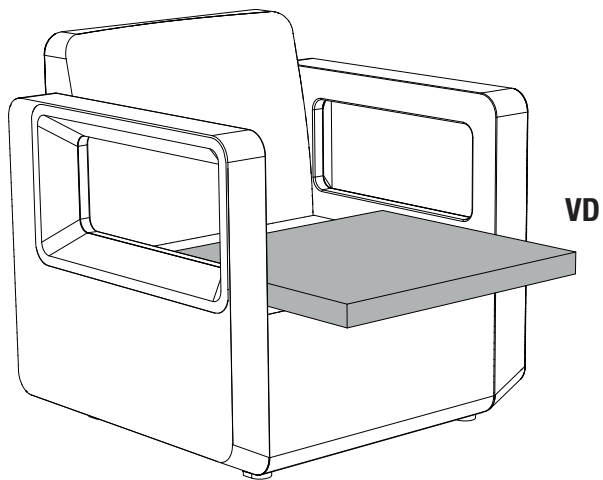

Sofá símil rattan
Rattan style Couch
Sofa aspect rotin
Rattan stil Sofa

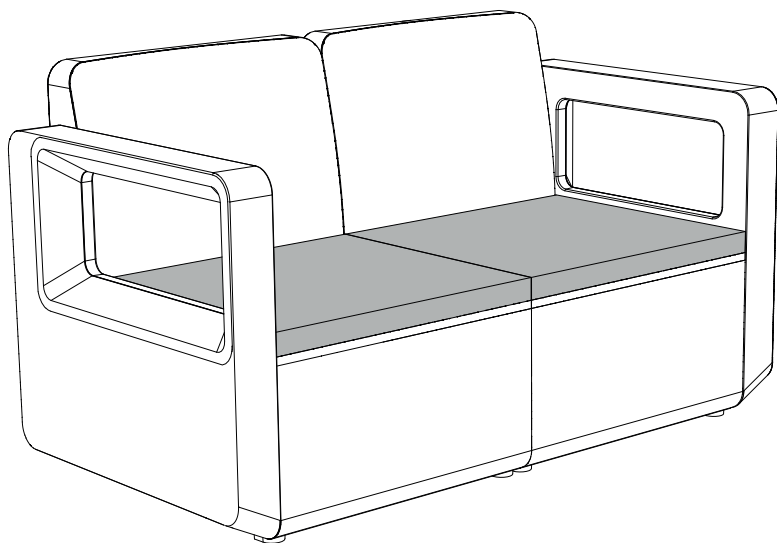

ASSEMBLY PARTS - COMPOSANTS-COMONENTES- BESTANDTEILE

A

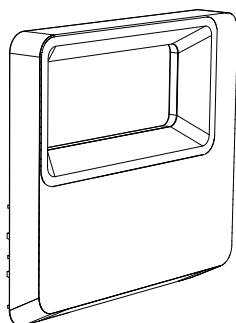

B

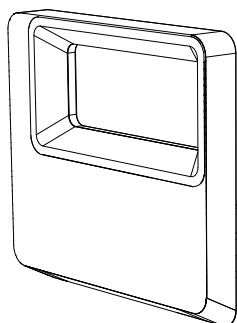

C

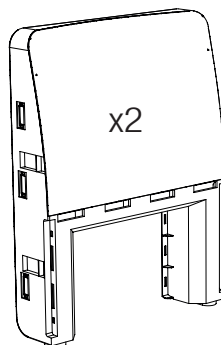

D

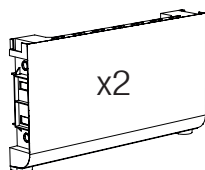

E



G

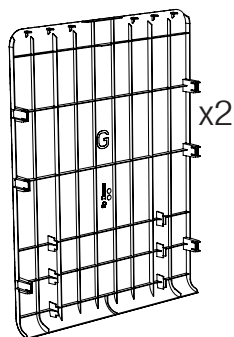

H

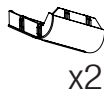

I

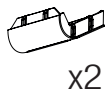

N

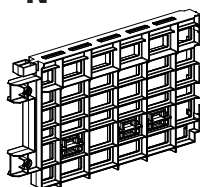

S



U

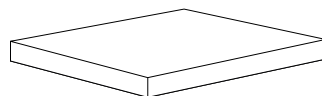

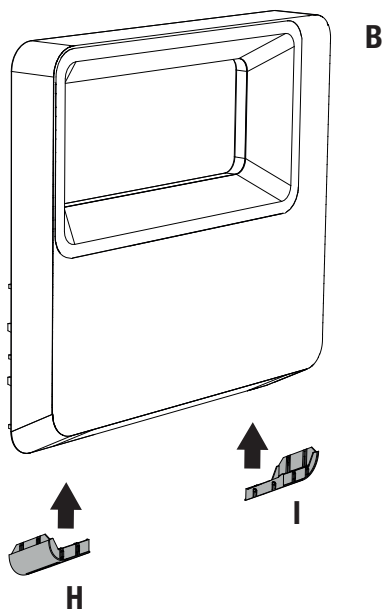
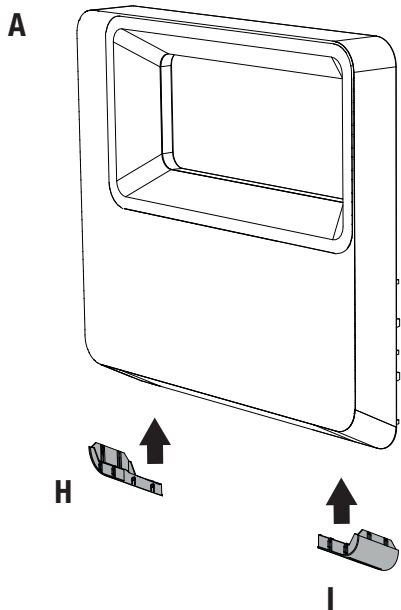

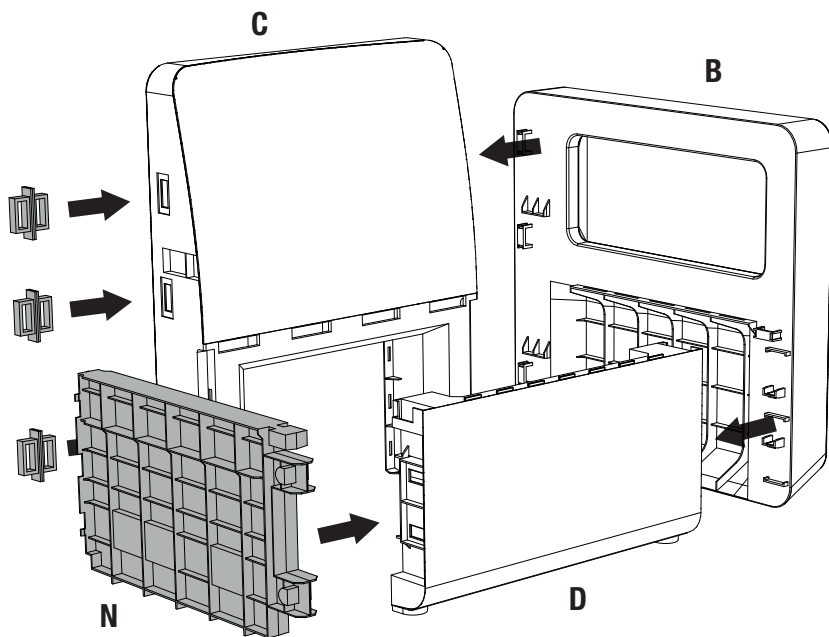
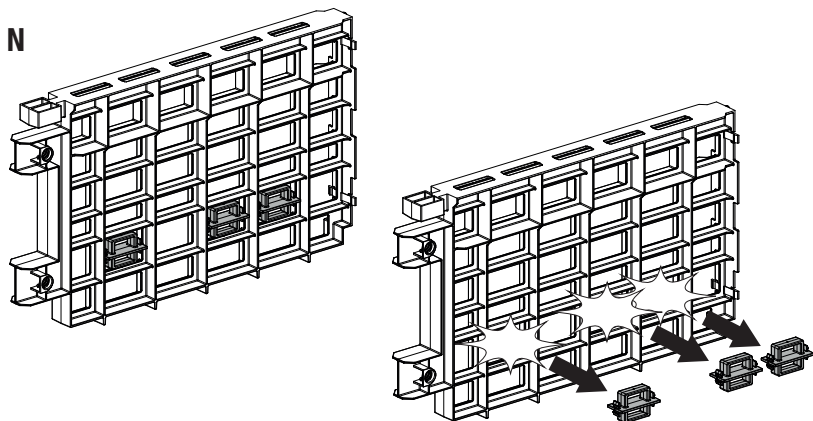

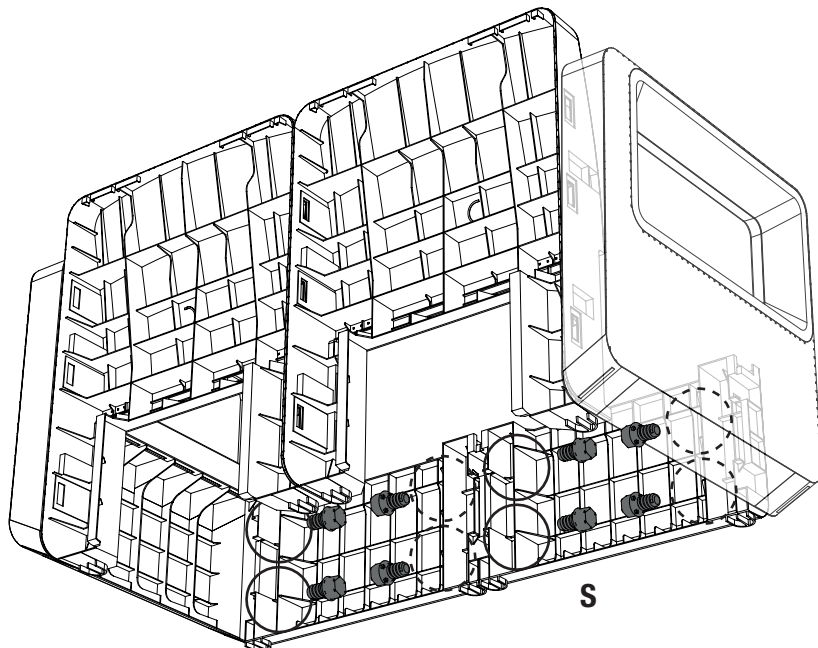
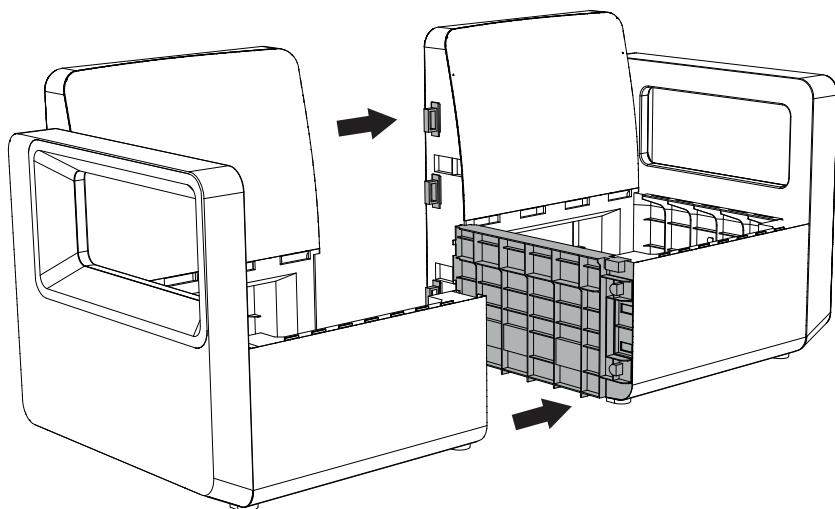

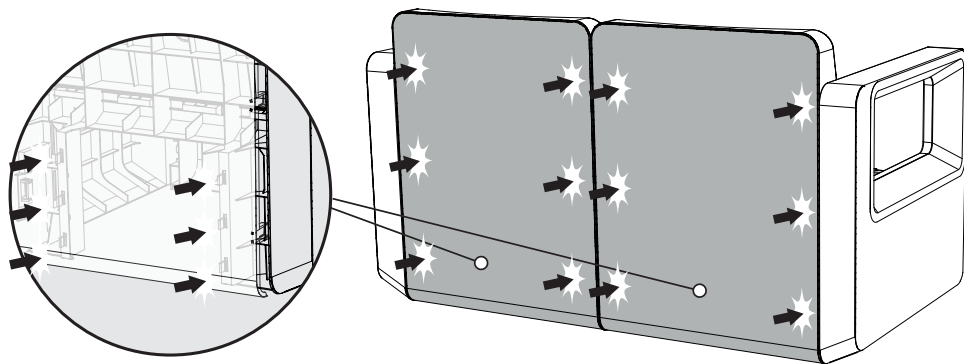
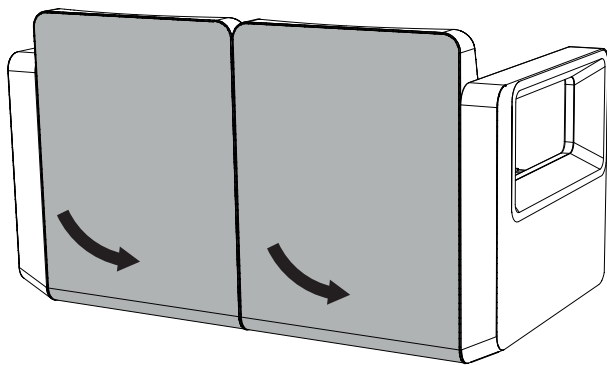
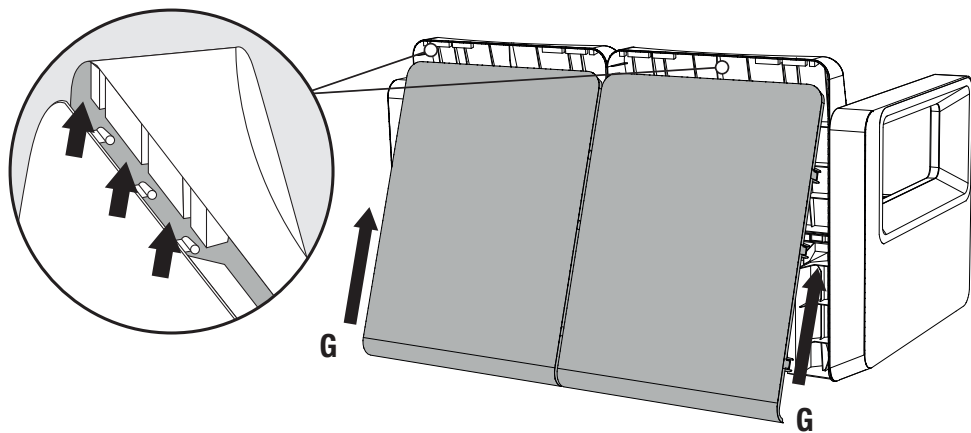

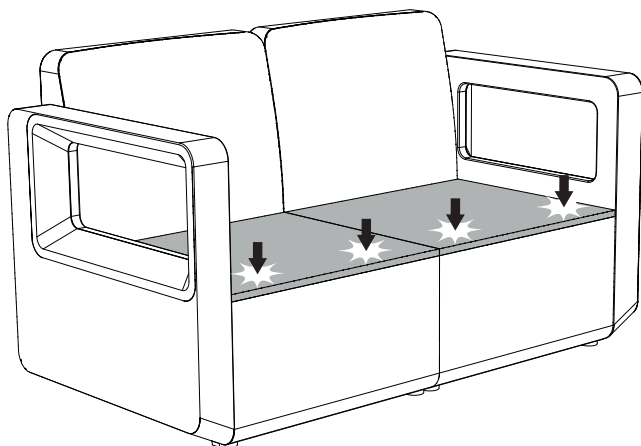
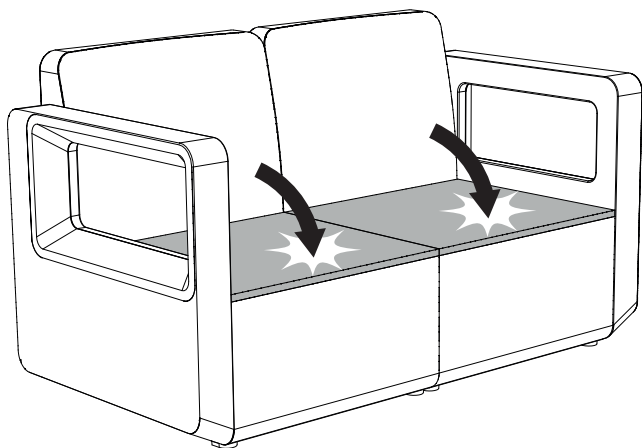
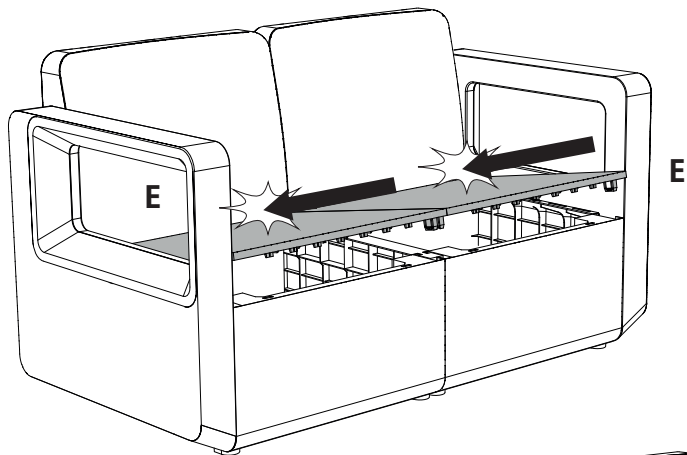

Mesa símil rattan
Rattan style table
Table aspect rotin
Rattan stil Tisch

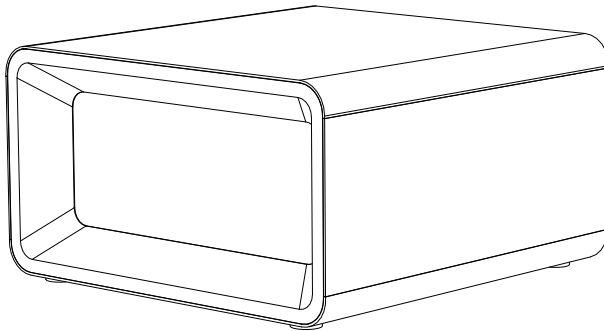

K



1x

L

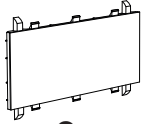

2x

J

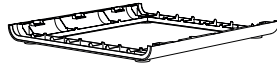

1x

FM

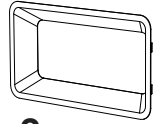

2x

K

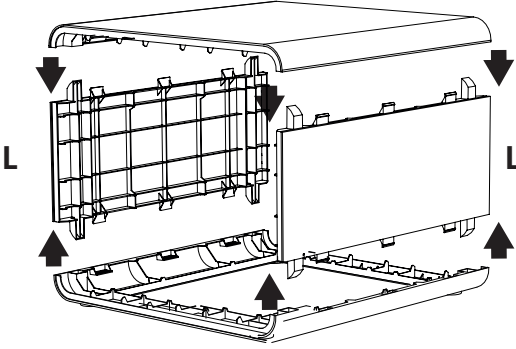

J

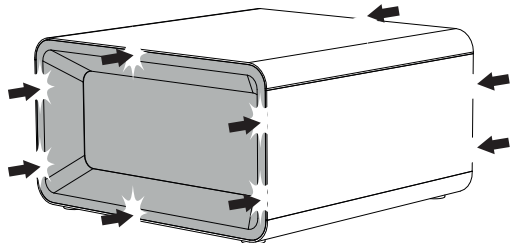
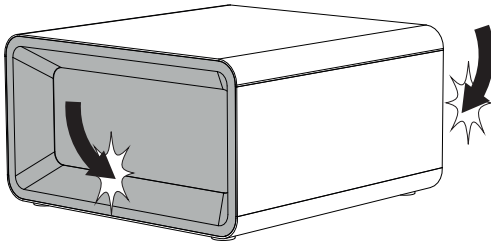
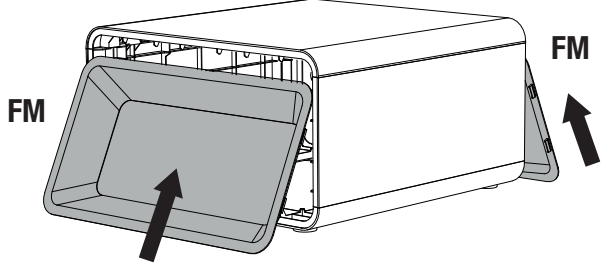

APOLO

C O N F O R T



FABRICADO EN ESPAÑA
MADE IN SPAIN
PRODOTTO IN SPAGNA
FABRIQUÉ EN ESPAGNE
FABRICADO NA ESPANHA
HERGESTELLT IN SPANIEN

Sp-Berner Plastic Group SL
Cno. de la Lloma, 35,
46960, Valencia, Spain,
B-96480454
www.sp-berner.com